

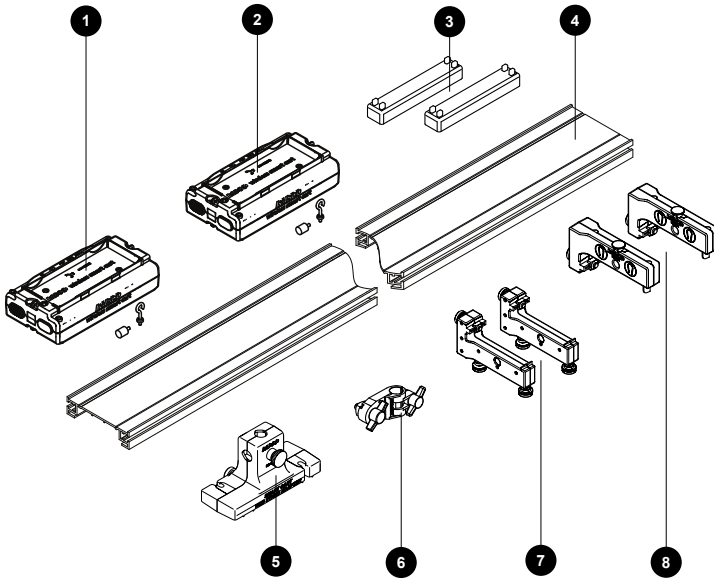

Basic Smart Cart Metal Track 1.2-m System

ME-5708A

Product Description



What's Included

- | | |
|---|--|
| 1 Smart Cart (Red)
ME-1240 | 5 Smart Cart Rod Stand Adapter
ME-1244 |
| 2 Smart Cart (Blue)
ME-1241 | 6 Track Rod Clamp
ME-9836 |
| 3 Cart Mass (set of 2)
ME-6757A | 7 Dynamics Track Feet (Pair)
ME-8972 |
| 4 1.2 m Aluminum Dynamics Track
ME-9493 | 8 Track End Stop (2 Pack)
ME-8971 |

What's Required

- PASCO Capstone or SPARKvue Software

Equipment Overview

This section provides a brief overview on how to use the equipment included with the dynamics system. For more detailed information, see the instruction manual included with each product.

Smart Cart Features

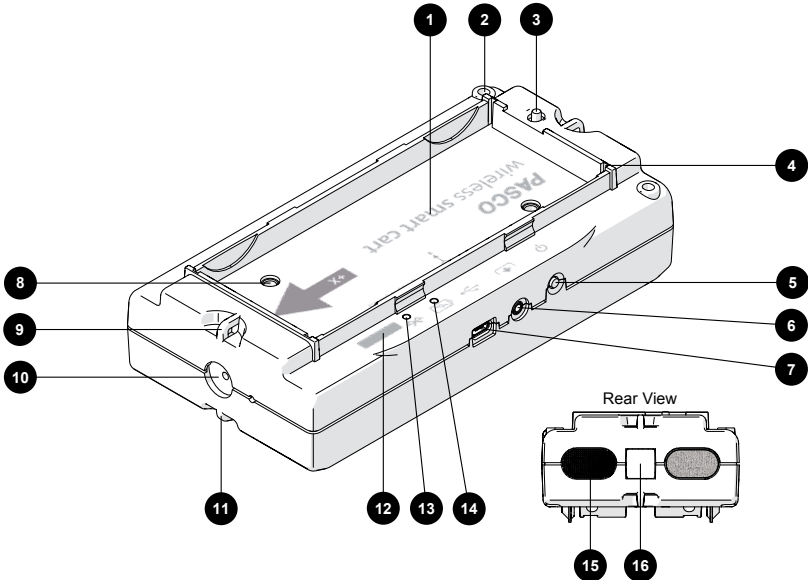

1 Accessory Tray

For placing accessories such as cart masses.

2 Accessory Hole

For attaching accessories such as the fan cart sail.

3 Plunger Release

Press to release the plunger at the rear of the cart.

4 Accessory Tray Slot

For attaching accessories such as a Cart Picket Fence (ME-9804) or Angle Indicator (ME-9495A).

5 Power Button

Press and hold for one second to power the cart on or off.

6 Accessory Port

For connecting Smart Cart accessories such as the Smart Fan (ME-1242), Smart Ballistic Cart (ME-1245), and Vector Display (ME-1246).

7 USB Port

For charging the battery by connecting the cart to a USB charger or the Smart Cart Charging Garage (ME-1243).

8 Threaded Hole (M5)

For securing accessories in the tray such as the Smart Cart Rod Stand Adapter (ME-1244).

9 Upper Tie Point

For attaching string or a spring to the cart. Springs included with the IDS Spring Kit (ME-8999) are designed to be used with carts.

10 Force Sensor

For attaching force sensor accessories such as the included hook, rubber bumper, and magnetic bumper. Additional accessories include spring bumpers and a clay cup in the Bumper Accessory Set (ME-9884).

11 Lower Tie Point

For attaching string that can run under an end stop, another cart, or a Motion Sensor

12 Sensor ID

Refer this ID when connecting the Smart Cart to software.

13 Bluetooth Status Light

Indicates the wireless connection status of the cart.

Red blink	Disconnected
Green blink	Connected

14 Battery Status Light

Indicates the battery charge level.

Red blink	Low charge
Green solid	Fully charged
Yellow solid	Charging

15 Velcro® Fastener

Allows cart to attach during collisions.

16 Plunger

Use to launch the cart or to push two carts apart with three different forces.

Dynamics Track Features

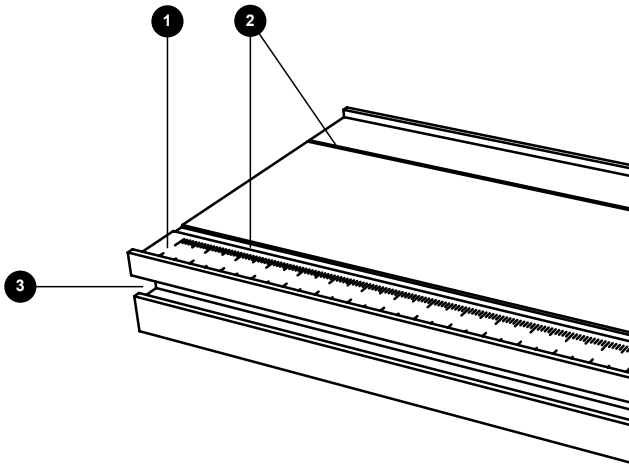

1 Metric Scale

Use the scale to measure cart positions.

2 Grooves

For guiding the wheels of a PASCO dynamics cart.

3 T-slot

For attaching track accessories such as track feet and end stops.

Attach an End Stop to a Dynamics Track

The Adjustable End Stop is designed to be mounted to the end of a dynamics track to stop dynamics carts from rolling off the end of the track.

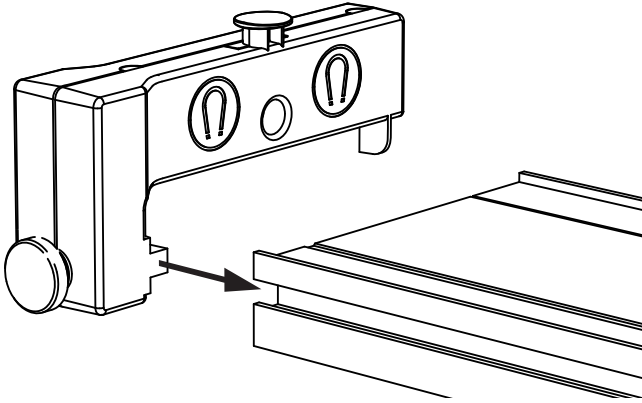

Figure 1. Installing the End Stop to a Dynamics Track.

1. Position the End Stop so that magnets on the End Stop face the track.
2. Insert the square nut and tab on the End Stop into the T-slot of the track.
3. Move the End Stop to the desired position then turn the thumbscrew to secure the end stop to the track.

Attach Feet to the Dynamics Track

The Track Feet are used to level a Dynamics Track by adjusting the height of the feet screws.

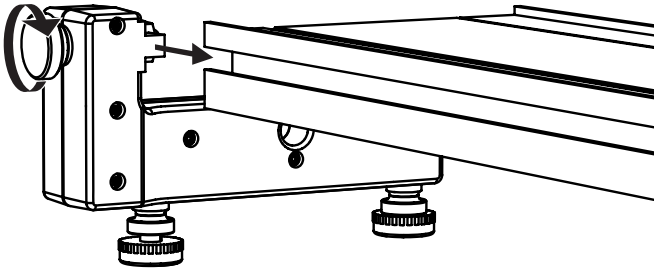

Figure 2. Installing the Track Feet to a Dynamics Track.

1. Insert the square nut and tab on the Track Feet into the T-slot of the track.
2. Move the feet to the desired position then turn the thumbscrew to secure the feet to the track.

TIP: For maximum stability, position the feet about $\frac{1}{4}$ of the track length from each end of the track.

3. Turn the feet screws to level the track then turn the lock nut to secure the feet screws.

Mount a Smart Cart to a Rod

The Smart Cart Rod Stand Adapter allows the PASCO Smart Cart to be suspended from a rod to use its force sensor to measure forces. The adapter contains two holes that are perpendicular to each other that allows the Smart Cart to be mounted vertically or horizontally.

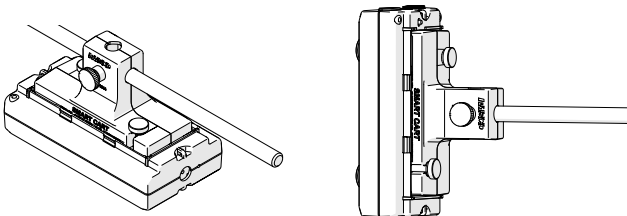

Figure 3. Two ways to mount the Smart Cart to a support rod using the Smart Cart Rod Stand Adapter.

Attach the Track Rod Clamp to a Dynamics Track

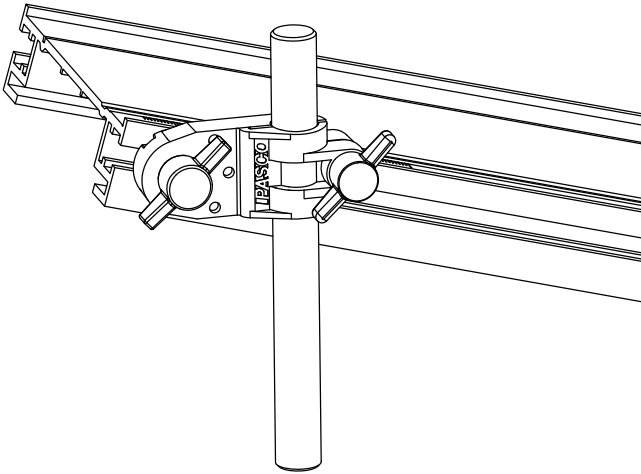

Figure 4. A Track Rod Clamp attached to a Dynamics Track and support rod.

The Track Rod Clamp is used to elevate a PASCO Dynamics Track to create an incline. The clamp holds the track to a support rod. To attach the clamp to a track:

1. Insert the square nut on the clamp into the T-slot of the dynamics track.
2. Insert a 0.5 inch rod into the clamp.
3. Adjust the track and clamp until the track is placed at the desired angle.

TIP: Place the clamp as close to the inclined end of the track as possible for stability.

4. Turn each thumbscrew to secure the clamp to the rod and track.

Using the Masses with a Cart

The Cart Masses are designed to be placed in the tray of any PASCO dynamics cart. One mass has approximately the same mass as a single plastic cart (including the Smart Cart) and half the mass of a metal cart. The cart tray can accommodate two masses. Add additional masses by stacking the bars. The built-in grooves on the bottom of the bars keep the masses in place.

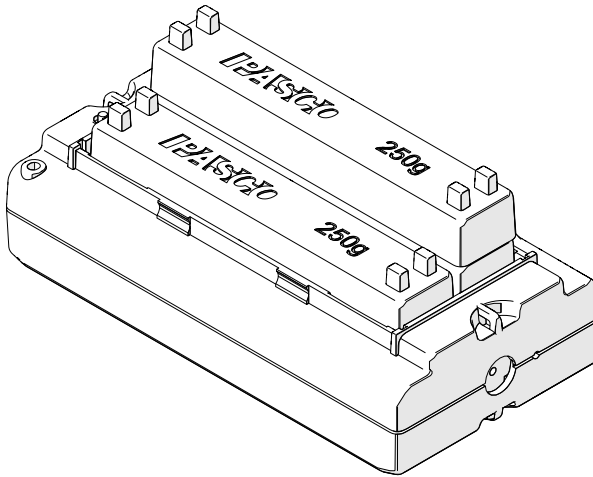

Figure 5. A Smart Cart holding stacked cart masses

Experiments

Print-ready experiment worksheets for this product are available to download from the PASCO website. Go to www.pasco.com/freelabs and enter **ME-5708A** to access all experiments related to this product.

Appendix

Technical Support

Contact PASCO Technical Support for assistance with this or any other PASCO product.

Address	PASCO scientific 10101 Foothills Blvd. Roseville, CA 95747-7100
Phone	1-800-772-8700 (USA) 1-916-462-8384 (International)
Chat	www.pasco.com
email	support@pasco.com

Warranty, Copyright, and Trademarks

Limited Warranty

For a description of the product warranty, see the Warranty and Returns page at www.pasco.com/legal.

Copyright

This document is copyrighted with all rights reserved. Permission is granted to non-profit educational institutions for reproduction of any part of this manual, providing the reproductions are used only in their laboratories and classrooms, and are not sold for profit. Reproduction under any other circumstances, without the written consent of PASCO scientific, is prohibited.

Trademarks

PASCO and PASCO scientific are trademarks or registered trademarks of PASCO scientific, in the United States and/or in other countries. All other brands, products, or service names are or may be trademarks or service marks of, and are used to identify, products or services of, their respective owners. For more information visit www.pasco.com/legal.

Product End of Life Disposal Instructions



This electronic product is subject to disposal and recycling regulations that vary by country and region. It is your responsibility to recycle your electronic equipment per your local environmental laws and regulations to ensure that it will be recycled in a manner that protects human health and the environment. To find out where you can drop off your waste equipment for recycling, please contact your local waste recycle or disposal service, or the place where you purchased the product.

The European Union WEEE (Waste Electronic and Electrical Equipment) symbol and on the product or its packaging indicates that this product must not be disposed of in a standard waste container.

Battery Disposal Instructions

Batteries contain chemicals that, if released, may affect the environment and human health. Batteries should be collected separately for recycling and recycled at a local hazardous material disposal location adhering to your country and local government regulations. To find out where you can drop off your waste battery for recycling, please contact your local waste disposal service, or the product representative. The battery used in this product is marked with the International symbols to indicate the need for the separate collection and recycling of batteries.

FCC Statement

This Class A digital device complies with part 15 of the FCC Rules. Operation is subject to the following two conditions: (1) This device may not cause harmful interference, and (2) this device must accept any interference received, including interference that may cause undesired operation.

CE Statement

This device has been tested and found to comply with the essential requirements and other relevant provisions of the applicable EU Directives.