

***Instruction Manual and
Experiment Guide for the
PASCO scientific
Model TD-8578***

012-07114D

THERMAL EXPANSION APPARATUS

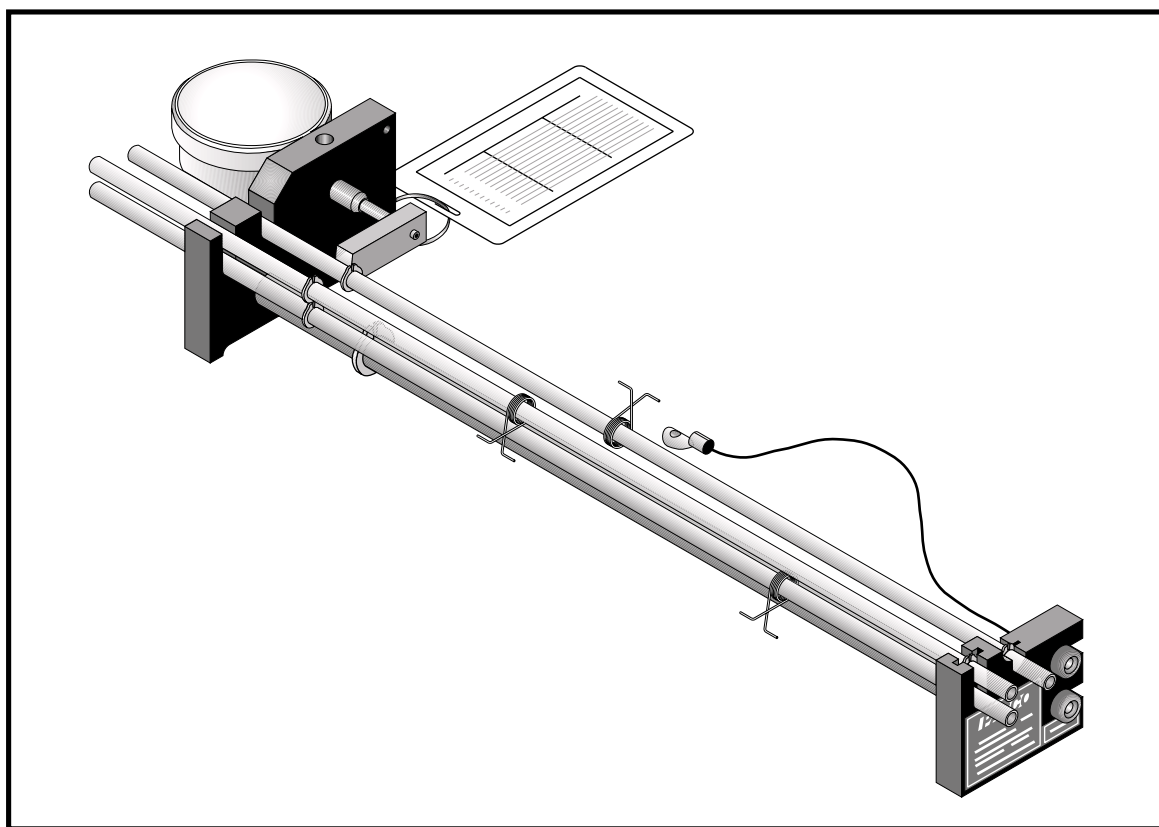

© 1999 PASCO scientific

PASCO®

10101 Foothills Blvd. • Roseville, CA 95747-7100
Phone (916) 786-3800 • FAX (916) 786-8905 • www.pasco.com

better
ways to
teach science

Table of Contents

Section	Page
Copyright, Warranty and Equipment Return	ii
INTRODUCTION:	
Equipment	1
Additional Equipment Required	1
Notes on Temperature Measurement	1
Accepted Values for Coefficient of Thermal Expansion	2
Changing Tubes	2
Replacement Parts	2
EXPERIMENT:	
Measuring the Coefficient of Linear Expansion for Copper, Brass, and Aluminum:	
Introduction	3
Procedure	3
Data and Calculations	4
Questions	5
Thermistor Conversion Table:	5
Technical Support	7

Copyright, Warranty and Equipment Return

Please—Feel free to duplicate this manual subject to the copyright restrictions below.

Copyright Notice

The PASCO scientific 012-07114 Thermal Expansion manual is copyrighted and all rights reserved. However, permission is granted to non-profit educational institutions for reproduction of any part of the manual providing the reproductions are used only for their laboratories and are not sold for profit. Reproduction under any other circumstances, without the written consent of PASCO scientific, is prohibited.

Limited Warranty

PASCO scientific warrants the product to be free from defects in materials and workmanship for a period of one year from the date of shipment to the customer. PASCO will repair or replace at its option any part of the product which is deemed to be defective in material or workmanship. The warranty does not cover damage to the product caused by abuse or improper use. Determination of whether a product failure is the result of a manufacturing defect or improper use by the customer shall be made solely by PASCO scientific. Responsibility for the return of equipment for warranty repair belongs to the customer. Equipment must be properly packed to prevent damage and shipped postage or freight prepaid. (Damage caused by improper packing of the equipment for return shipment will not be covered by the warranty.) Shipping costs for returning the equipment after repair will be paid by PASCO scientific.

Equipment Return

Should the product have to be returned to PASCO scientific for any reason, notify PASCO scientific by letter, phone, or fax BEFORE returning the product. Upon notification, the return authorization and shipping instructions will be promptly issued.

► **NOTE:** NO EQUIPMENT WILL BE ACCEPTED FOR RETURN WITHOUT AN AUTHORIZATION FROM PASCO.

When returning equipment for repair, the units must be packed properly. Carriers will not accept responsibility for damage caused by improper packing. To be certain the unit will not be damaged in shipment, observe the following rules:

- ① The packing carton must be strong enough for the item shipped.
- ② Make certain there are at least two inches of packing material between any point on the apparatus and the inside walls of the carton.
- ③ Make certain that the packing material cannot shift in the box or become compressed, allowing the instrument come in contact with the packing carton.

Address: PASCO scientific
10101 Foothills Blvd.
Roseville, CA 95747-7100

Phone: (916) 786-3800
FAX: (916) 786-3292
email: techsupp@pasco.com
web: www.pasco.com

Introduction

Introduction

The PASCO Model TD-8578 Thermal Expansion Apparatus provides easy and accurate measurements of the coefficient of linear expansion for brass, copper, and aluminum.

To make the measurement, the brass, copper, or aluminum tube is placed on the expansion base. The length of the tube is measured at room temperature, then steam is passed through it. The expansion of the metal is measured with 0.01 mm resolution using the built-in dial-gauge. Temperatures are measured to within 0.2 °C using a thermistor attached to the center of the tube. If you wish to investigate the expansion of the metals at additional temperatures, hot or cold water can be passed through the tubes.

Complete step by step instructions and a data sheet for results are provided on the following pages.

Equipment

Your TD-8578 Thermal Expansion Apparatus includes:

- A 40 cm long expansion base with a built-in dial gauge and thermistor.

► **NOTE:** The dial gauge can be removed or repositioned by loosening the set screw on the dial gauge mounting block.

- Three metal tubes — brass, copper (99.5% Cu, 0.5% Te), and aluminum (98.9% Al, 0.7% Mg, 0.4% Si): 6.4 mm outside diameter.
- A foam insulator to avoid heat loss at the thermistor connection point.
- Thermoplastic elastometer tubing with 6.4 mm I.D.

Additional Equipment Required

In addition to the TD-8578 Thermal Expansion Apparatus, the following items are needed to perform the experiment:

- ① A source of steam or hot water, such as the PASCO Model TD-8556A Steam Generator.
- ② A digital ohmmeter such as PASCO Model SE-9589 to measure the thermistor resistance. Leads should have banana plug connectors, such as PASCO Model SE-9750 or SE-9751 Patch Cords.
- ③ A container to catch the water as it drains out of the tube.
- ④ If additional data points are desired you will also need: a source of hot or cold water.

Notes on Temperature Measurement

A thermistor's resistance varies reliably with temperature. The resistance can be measured with an ohmmeter, and converted to a temperature measurement using the attached conversion table tag and also on the back page of this manual. Although the relationship between temperature and resistance is not linear, a linear approximation can be accurately used to interpolate between table data points with an accuracy of approximately ± 0.2 °C.

The thermistor used to measure the tube temperature is embedded in the thermistor lug. Once thermal equilibrium has been reached, the heat is highly uniform along the length of the tube. The foam insulator is used to inhibit heat loss through the thermistor lug so the lug temperature closely follows the tube temperature. The insulator does not have any appreciable effect on the local temperature of the tube itself.

Accepted Values for Coefficient of Thermal Expansion

Material	α ($\times 10^{-6}/^{\circ}\text{C}$)
Copper	17
Brass	19
Aluminum	23

Changing Tubes

► **Caution:** When changing tubes, be careful not to pull the wires off of the thermistor.

- ① Compress the capture spring by pressing the two ends together.
- ② Insert the curved lug of the thermistor between the capture spring and the thermal tube.
- ③ Release spring.

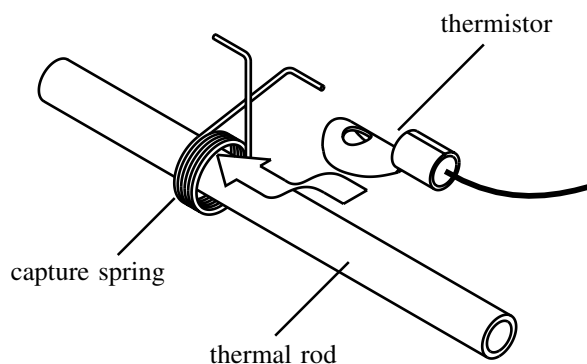

Replacement Parts

The following parts can be ordered from PASCO scientific.

Item	PASCO #
Mod. Thermistor (100k Ω)	150-031
AL Tube	648-07139
Cu Tube	648-07141
Brass Tube	648-07140
Foam Insulator	716-041
Dial Gauge	620-050

Experiment: Measuring the Coefficient of Linear Expansion for Copper, Brass, and Aluminum

Introduction

Most materials expand when heated through a temperature range that does not produce a change in phase. The added heat increases the average amplitude of vibration of the atoms in the material, which increases the average separation between the atoms.

Suppose an object of length L undergoes a temperature change of magnitude ΔT . If ΔT is reasonably small, the change in length, ΔL , is generally proportional to L and ΔT . Stated mathematically:

$$\Delta L = \alpha L \Delta T;$$

where α is called the coefficient of linear expansion for the material.

Materials that are not isotropic, such as an asymmetric crystal for example, α can have a different value depending on the axis along which the expansion is measured.

α can also vary somewhat with temperature. Therefore, the degree of expansion depends not only on the magnitude of the temperature change, but on the absolute temperature as well.

In this experiment, you will measure α for copper, aluminum, and brass. These metals are isotropic, so it is necessary to measure α along only one dimension. Also, within the limits of this experiment, α does not vary with temperature.

Procedure

- ① Measure L , the length of the copper tube at room temperature. Measure from the outer edge of the stainless steel ring on one end, to the outer edge of the stainless steel ring at the other end (see Figure 1). Record your results in Table 1.

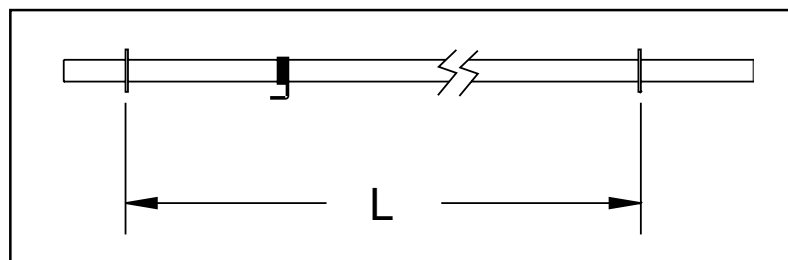

Figure 1 Measuring Tube Length

- ② Mount the copper tube in the expansion base as shown in Figure 2. The stainless steel ring on the tube fits into the slot on the slotted mounting block and the bracket on the tube presses against the spring arm of the dial gauge.

- ③ Use the capture spring on the expansion tube to attach the thermistor lug somewhere in the middle of the copper tube. The lug will be aligned with the axis of the tube, as shown in Figure 2, so there is maximum contact between the lug and the tube.

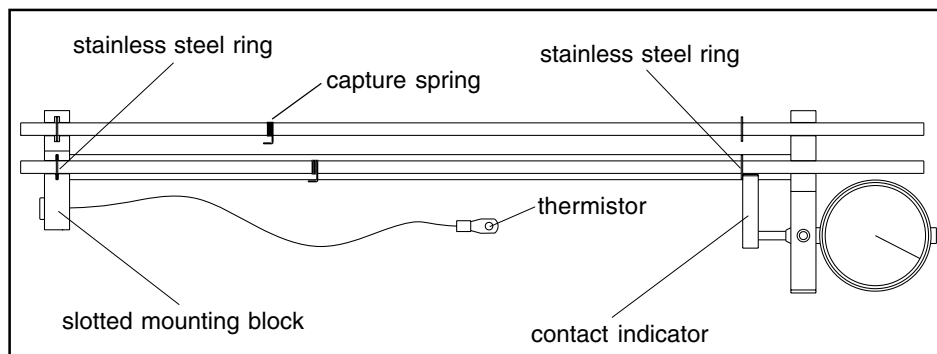

Figure 2 Equipment Setup (Top View)

- ④ Place the foam insulator over the thermistor lug.
- ⑤) Plug the leads of your ohmmeter into the banana plug connectors labeled THERMISTOR in the center of the expansion base. The banana plug connectors are located at one end of this unit in a stop bracket.
- ⑥ Measure and record R_{rm} , the resistance of the thermistor at room temperature. Record this value in the table.
- ⑦ Use tubing to attach your steam generator to the end of the copper tube. Attach it to the end closest to the dial gauge.
- ⑧ Place a container under the other end of the tube to catch the draining water.
- ⑨ Turn the outer casing of the dial gauge to align the zero point on the scale with the long indicator needle. As the tube expands, the indicator needle will move in a counterclockwise direction.
- ⑩) Turn on the steam generator. As steam begins to flow, watch the dial gauge and the ohmmeter. When the thermistor resistance stabilizes, record the resistance (R_{hot}) in Table 1. Also record the expansion of the tube length (ΔL) as indicated by the displacement of the indicator on the dial gauge. (Each increment on the dial gauge is equivalent to 0.01 mm of tube expansion.)

► Repeat the experiment for the brass and aluminum tubes.

Data and Calculations

TABLE 1 Data and Calculations

	DATA				CALCULATIONS		
	L(mm)	$R_{rm}(\Omega)$	$\Delta L(\text{mm})$	$R_{hot}(\Omega)$	$T_{rm}(\text{°C})$	$T_{hot}(\text{°C})$	$\Delta T(\text{°C})$
copper							
brass							
aluminum							

- ① Use the Thermistor Conversion Table on page 5 of this manual or on the tag attached to the apparatus. Convert your thermistor resistance measurements, R_{rm} and R_{hot} , into temperature measurements, T_{rm} and T_{hot} . Record your results in the table.

► Note: To achieve 0.2°C accuracy for temperature, you must interpolate between the temperature values listed in the Thermistor Conversion Table.

- ② Calculate $\Delta T = T_{\text{hot}} - T_{\text{rm}}$. Record the result in the table.
- ③ Using the equation $\Delta L = \alpha L \Delta T$, calculate α for copper, steel, and aluminum.

$$\alpha_{\text{Cu}} = \underline{\hspace{2cm}}$$

$$\alpha_{\text{Brass}} = \underline{\hspace{2cm}}$$

$$\alpha_{\text{Al}} = \underline{\hspace{2cm}}$$

Questions

- ① Look up the accepted values for the linear expansion coefficient for copper, brass, and aluminum. Compare these values with your experimental values. What is the percentage difference in each case? Is your experimental error consistently high or low?
- ② On the basis of your answers in question 1, speculate on the possible sources of error in your experiment. How might you improve the accuracy of the experiment?

THERMISTOR CONVERSION TABLE: Temperature versus Resistance

Res. (Ω)	Temp. ($^{\circ}\text{C}$)	Res. (Ω)	Temp. ($^{\circ}\text{C}$)	Res. (Ω)	Temp. ($^{\circ}\text{C}$)	Res. (Ω)	Temp. ($^{\circ}\text{C}$)
351,020	0	95,447	26	30,976	52	11,625	78
332,640	1	91,126	27	29,756	53	11,223	79
315,320	2	87,022	28	28,590	54	10,837	80
298,990	3	83,124	29	27,475	55	10,467	81
283,600	4	79,422	30	26,409	56	10,110	82
269,080	5	75,903	31	25,390	57	9,767.2	83
255,380	6	72,560	32	24,415	58	9,437.7	84
242,460	7	69,380	33	23,483	59	9,120.8	85
230,260	8	66,356	34	22,590	60	8,816.0	86
218,730	9	63,480	35	21,736	61	8,522.7	87
207,850	10	60,743	36	20,919	62	8,240.6	88
197,560	11	58,138	37	20,136	63	7,969.1	89
187,840	12	55,658	38	19,386	64	7,707.7	90
178,650	13	53,297	39	18,668	65	7,456.2	91
169,950	14	51,048	40	17,980	66	7,214.0	92
161,730	15	48,905	41	17,321	67	6,980.6	93
153,950	16	46,863	42	16,689	68	6,755.9	94
146,580	17	44,917	43	16,083	69	6,539.4	95
139,610	18	43,062	44	15,502	70	6,330.8	96
133,000	19	41,292	45	14,945	71	6,129.8	97
126,740	20	39,605	46	14,410	72	5,936.1	98
120,810	21	37,995	47	13,897	73	5,749.3	99
115,190	22	36,458	48	13,405	74	5,569.3	100
109,850	23	34,991	49	12,932	75		
104,800	24	33,591	50	12,479	76		
100,000	25	32,253	51	12,043	77		

Notes

Technical Support

Feedback

If you have any comments about the product or manual, please let us know. If you have any suggestions on alternate experiments or find a problem in the manual, please tell us. PASCO appreciates any customer feedback. Your input helps us evaluate and improve our product.

To Reach PASCO

For technical support, call us at 1-800-772-8700 (toll-free within the U.S.) or (916) 786-3800.

fax: (916) 786-3292

e-mail: techsupp@pasco.com

web: www.pasco.com

Contacting Technical Support

Before you call the PASCO Technical Support staff, it would be helpful to prepare the following information:

- ▶ If your problem is with the PASCO apparatus, note:
 - Title and model number (usually listed on the label);
 - Approximate age of apparatus;
 - A detailed description of the problem/sequence of events (in case you can't call PASCO right away, you won't lose valuable data);
 - If possible, have the apparatus within reach when calling to facilitate description of individual parts.
- ▶ If your problem relates to the instruction manual, note:
 - Part number and revision (listed by month and year on the front cover);
 - Have the manual at hand to discuss your questions.