

# SPARKlink Air

PS-2011

Made for

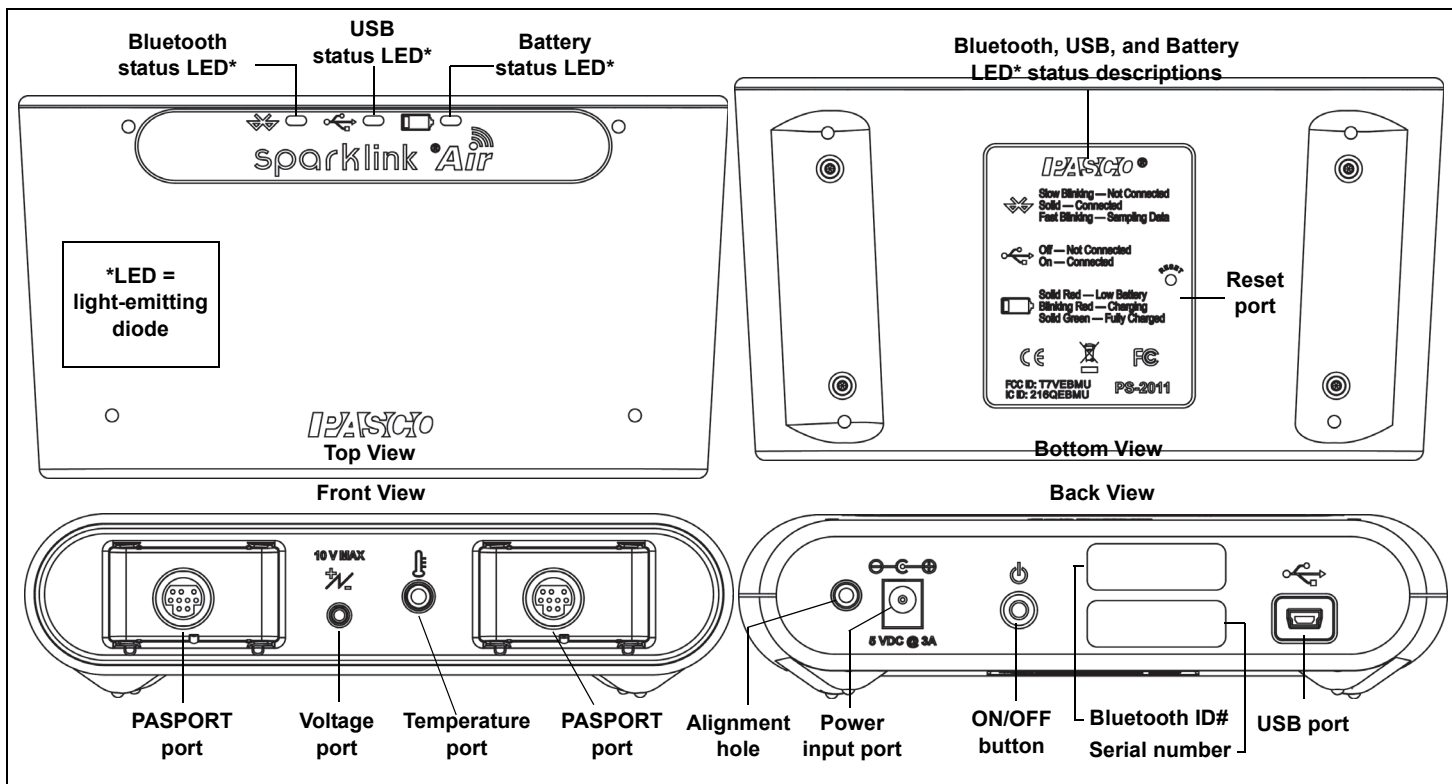

## Hardware

Included Equipment	Part Number
SPARKlink Air	PS-2011
Temperature Probe	PS-2135
Voltage Probe	PS-2165
USB Cable	PS-2528
AC Adapter/Power Cord	

### Initial Step: Charge the Battery

See page 2 for the procedure.

## Data Collection Software<sup>1</sup>

PASCO Capstone

SPARKvue\*



- Mac OS X
- Windows

- Mac OS X
- Windows
- iOS
- Android

(Capstone UI-5400)

(SPARKvue PS-2400)

<sup>1</sup>See the PASCO web site at [www.pasco.com/software](http://www.pasco.com/software) for more information about PASCO data collection software

\*NOTE: SPARKvue also supports a Chromebook device that is connected to SPARKlink Air through USB.

## Charge the Battery

The SPARKlink Air interface's battery is partially charged at the factory. SPARKlink Air off while charging. As the battery is charging, the Battery Status LED (light emitting diode) will blink red. When the battery is fully charged, the Battery Status LED shines green. The charger circuit inside the unit turns itself off when the unit is fully charged, so it can't be overcharged.

The SPARKlink Air battery can also be charged using the USB cable connected to a USB port, or by mounting the SPARKlink Air in a slot on the SPARKlink Air Charging Station (PS-2577). When the SPARKlink Air is disconnected from the charger, USB cable, or charging station, the Battery Status LED goes out.

### Battery Life

The interface will normally provide 4 to 6 hours of continuous data collection between charges depending on the power demand of the connected sensor and the sampling rate.

The SPARKlink Air Charging Station can charge up to five SPARKlink Air interfaces using a single power source. To mount the SPARKlink Air, line up the alignment hole on the back of the SPARKlink Air with the pin in any slot on the charging station, and press the interface into the slot.



## Introduction

SPARKlink Air is a sensor interface with two ports to accept PASPORT sensors and other ports for the included Voltage Probe and Temperature Probe.

The SPARKlink Air interface connects to a computer or tablet device wirelessly via Bluetooth, or can also connect to a computer's USB port with the included USB cable.

### Connecting SPARKlink Air to a Tablet or a Computer via Bluetooth

- For information about SPARKlink Air and Bluetooth, see the PASCO web site page [www.pasco.com/air](http://www.pasco.com/air). Check "User Resources" for information about using Bluetooth to connect the SPARKlink Air to the iOS device or an Android™ tablet, or to a Windows or Macintosh computer.
- Follow the specific Bluetooth protocol for your device to "pair" it with the SPARKlink Air. The identification number (ID#) for the SPARKlink Air is printed on a label on the back of the interface.

### Connecting SPARKlink Air to a Computer with a USB Cable

- Connect the small end of the included USB cable into the USB port on the back of the SPARKlink Air interface.
- Connect the other end of the USB cable to a USB port on the computer, or into a USB hub connected to the computer.
- To turn on the SPARKlink Air, press and briefly **hold** the ON/OFF button on the back. After all three status LEDs blink in sequence, **release** the ON/OFF button.
  - The USB Status LED will shine green. (**NOTE:** The Bluetooth Status LED will slowly blink blue. The Battery Status LED **may** also blink red to indicate that the battery is charging through the USB cable.)

### Connecting a Sensor

Plug a PASPORT sensor or a PASPORT sensor cable into a PASPORT input port on the front of the interface.

**NOTE:** PASCO Data Collection software automatically detects each sensor when you connect it to the interface.

- See the SPARKvue or PASCO Capstone Users Guides for information about collecting, displaying, and analyzing data.

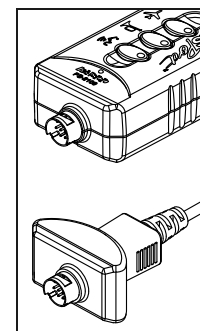

### Battery Removal/Replacement

If the SPARKlink Air interface fails to recharge, the battery may need to be replaced. Order the **PS-2569 Replacement Battery**. The tool that is required is the T8 (Torx) screw driver. Remove the four Torx-head screws from the bottom of the interface. Disconnect the battery cable, and remove the Lithium-Polymer (Li-Poly) battery pack. Reverse these steps to replace the battery.

### Troubleshooting the SPARKlink Air

- If the SPARKlink Air interface is unable to charge using the USB cable connected to a USB port, then charge the device with the included AC Adapter/Power Cord.
- If the SPARKlink Air interface loses Bluetooth connection and will not reconnect, try cycling the ON/OFF button. Press and briefly **hold** the button until the status LED's blink in sequence, and then release the button to turn the interface off.
- If the interface stops communicating with the computer software or tablet application, try restarting the software or application. If the problem remains, try cycling the ON/OFF button.

- As a last resort, push a pin into the Reset port on the bottom of the interface.
- **NOTE:** When the SPARKlink Air is turned off, the most recent sample of data will be lost.

## Technical Support

For assistance with any PASCO product, contact PASCO at:

Address: PASCO scientific  
10101 Foothills Blvd.  
Roseville, CA 95747-7100

Phone: +1 916 462 8384 (worldwide)  
877-373-0300 (U.S.)

Web: [www.pasco.com](http://www.pasco.com)

Email: [support@pasco.com](mailto:support@pasco.com)

For more information about the product and the latest revision of this Reference Guide, visit the PASCO web site at [www.pasco.com](http://www.pasco.com) and enter “SPARKlink Air” or the product number in the Search window.

### Limited Warranty

For a description of the product warranty, see the PASCO catalog.

### Copyright

The PASCO scientific 013-13807C *SPARKlink Air Reference Guide* is copyrighted with all rights reserved. Permission is granted to non-profit educational institutions for reproduction of any part of this manual, providing the reproductions are used only in their laboratories and classrooms, and are not sold for profit. Reproduction under any other circumstances, without the written consent of PASCO scientific, is prohibited.

### Trademarks

PASCO, PASCO scientific, PASCO Capstone, PASPORT, SPARKvue, and SPARKvue HD are trademarks or registered trademarks of PASCO scientific, in the United States and/or in other countries. All other brands, products, or service names are or may be trademarks or service marks of, and are used to identify, products or services of their respective owners. For more information visit [www.pasco.com/legal](http://www.pasco.com/legal).

### iPod touch, iPhone and iPad

“Made for iPod”, “Made for iPhone” and “Made for iPad” means that an electronic accessory has been designed to connect specifically to iPod, iPhone, or iPad, respectively, and has been certified by the developer to meet Apple performance standards. Apple is not responsible for the operation of this device or its compliance with safety and regulatory standards.

iPad, iPad Air, and iPad mini are trademarks of Apple, Inc, registered in the U.S. and other countries.

### FCC Statement

This Class A digital device complies with part 15 of the FCC Rules. Operation is subject to the following two conditions: (1) This device may not cause harmful interference, and (2) this device must accept any interference received, including interference that may cause undesired operation.

### CE Statement

This device has been tested and found to comply with the essential requirements and other relevant provisions of the applicable EU Directives.

### Product End of Life Disposal Instructions:

This electronic product is subject to disposal and recycling regulations that vary by country and region. It is your responsibility to recycle your electronic equipment per your local environmental laws and regulations to ensure that it will be recycled in a manner that protects human health and the environment. To find out where you can drop off your waste equipment for recycling, please contact your local waste recycle/disposal service, or the place where you purchased the product.

The European Union WEEE (Waste Electronic and Electrical Equipment) symbol (to the right) and on the product or its packaging indicates that this product **must not** be disposed of in a standard waste container.



### Battery Replacement and Disposal Instructions:

Batteries contain chemicals that, if released, may affect the environment and human health. Batteries should be collected separately for recycling, and recycled at a local hazardous material disposal location adhering to your country and local government regulations. To find out where you can drop off your waste battery for recycling, please contact your local waste disposal service, or the product representative.

### Removal/Replacement:

Order the PS-2569 Replacement Battery for SPARK Science Learning System. Tool required: T8 (Torx) screw driver. Remove the four Torx-head screws from the bottom of the interface. Disconnect the battery cable, and remove the Li-Poly battery pack. Reverse these steps to replace the battery.

The Lithium Polymer (Li-Poly) rechargeable battery used in this product is marked with the International symbols to indicate the need for the separate collection and recycling of batteries.



Li-Poly

